

TABLE OF CONTENTS

	<u>Page No.</u>
I. INTRODUCTION.....	2
II. PLANNING YOUR INSTALLATION.....	2
III. INSTALLING THE WEATHER PICTURE	4
WIRING DIAGRAMS.....	4
MOUNTING INSTRUCTIONS.....	11
ADJUST THE YEAR.....	12
SELECTING SERIAL DATA MODE.....	13
IV. SELECTING NUMERIC DISPLAY FUNCTIONS.....	14
SET DATE FORMAT.....	14
SET TIME FORMAT.....	14
SELECTING UNITS (US/Metric).....	14
V. ROUTINE MAINTENANCE.....	18
VI. WARRANTY.....	19
REPAIR & EXCHANGE SERVICE.....	19
VII. SPECIFICATIONS.....	20
VIII. AVAILABLE ACCESSORIES.....	21

I. INTRODUCTION

Congratulations on selecting THE WEATHER PICTURE. To take full advantage of its advanced features, please take a few minutes to read through and follow this short booklet. Its simple step-by-step instructions will speed you through installation and help assure you many years of complete satisfaction.

THE WEATHER PICTURE displays information it receives from an *ULTIMETER*[®] Weather Station, continuously providing and updating all the vital weather data you have pre-selected, without having to press a single key.

In addition to the compass rose Wind Direction Display, THE WEATHER PICTURE features up to seven red illuminated Numeric Displays. Each Numeric Display is easily pre-set by the user to display an individual item of weather data collected by an *ULTIMETER*[®] Weather Station. The displayed data is clearly labeled using easy-to-insert labels (provided) for a totally customized, totally professional display. Each Numeric Display can be set and labeled to show the exact data item and measurement units you desire.

THE WEATHER PICTURE is connected to the Serial Data Output Port of an *ULTIMETER*[®] Weather Station. Weather data sent to THE WEATHER PICTURE is constantly updated (as often as two times per second) to provide up-to-the-minute information on changing weather conditions.

II. PLANNING YOUR INSTALLATION

Please take a few minutes to plan the installation of your WEATHER PICTURE. You'll help assure your long term satisfaction with the installation and almost certainly save time and effort in the process.

The cable included with THE WEATHER PICTURE connects to the junction box of an *ULTIMETER*[®] 2100 Weather Station, or to the Keyboard/Display Unit of an *ULTIMETER*[®] 100/800/2000 Weather Station and an AC Adapter (included). The length of the Weather Picture cable is 25 feet, and the length of the AC Adapter cord is 6 feet, so plan to hang THE WEATHER PICTURE on a wall within 25 feet of the *ULTIMETER*[®] Keyboard/Display (or *ULTIMETER*[®] 2100 Junction Box) and near a 110v wall outlet.

If your installation requires greater distance between THE WEATHER PICTURE and the *ULTIMETER*[®] Keyboard/Display, an Extension Cable (40 feet) may be obtained (see "Available Accessories"). If no wall outlet is close enough to where you wish to hang THE WEATHER PICTURE, then use a properly-rated extension cord between the wall outlet and the AC Adapter.

Getting Ready

1. Carefully remove all components from the shipping container and place them all on a clear work area.
2. As shown below, identify the basic WEATHER PICTURE components and any accessories (extension cables or additional Numeric Display Modules) you have ordered.

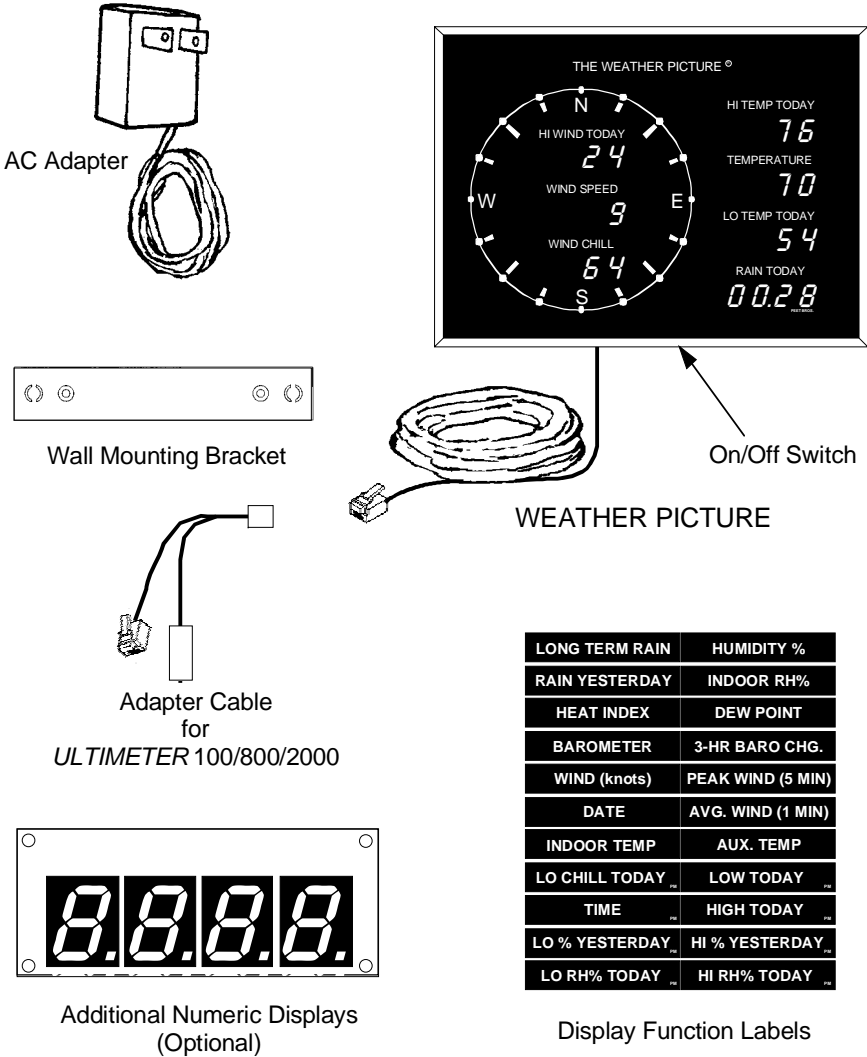

Not shown: 2 screws + 2 wall anchors for Wall Mounting Bracket; and screws for any additional Numeric Displays ordered.

WIRING DIAGRAM B

If you have an *ULTIMETER* 2100 with Unimount Sensor Array, or an *ULTIMETER* II, 100, 500, 800, or 2000 with no other accessories connected to the keyboard's serial port, connect components as shown in the following diagram. Use Adapter Cable provided.

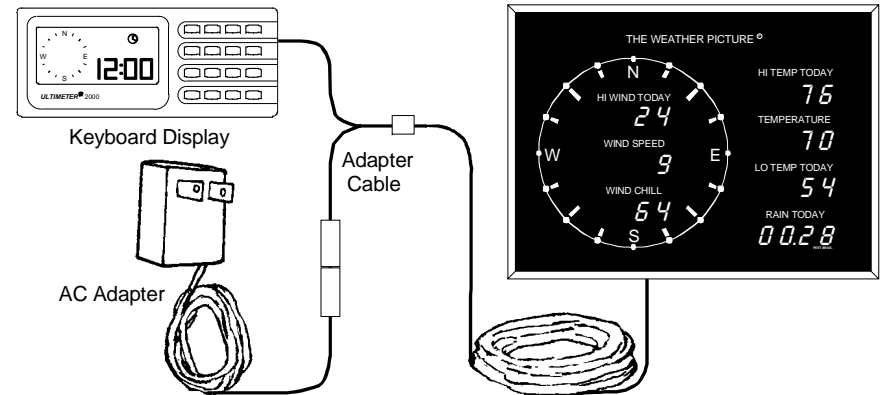

NOTE: BEFORE YOU INSTALL PLUGS IN RECEPTACLES, be sure to check connectors as shown on p. 11.

WIRING DIAGRAM C

If you have an *ULTIMETER* 2100 with Unimount Sensor Array, or an *ULTIMETER* II, 100, 500, 800, or 2000 with no other accessories connected to the keyboard's serial port, but need additional cable length to the keyboard's serial port or AC wall outlet, connect components as shown in the following diagram. Use Adapter Cable provided.

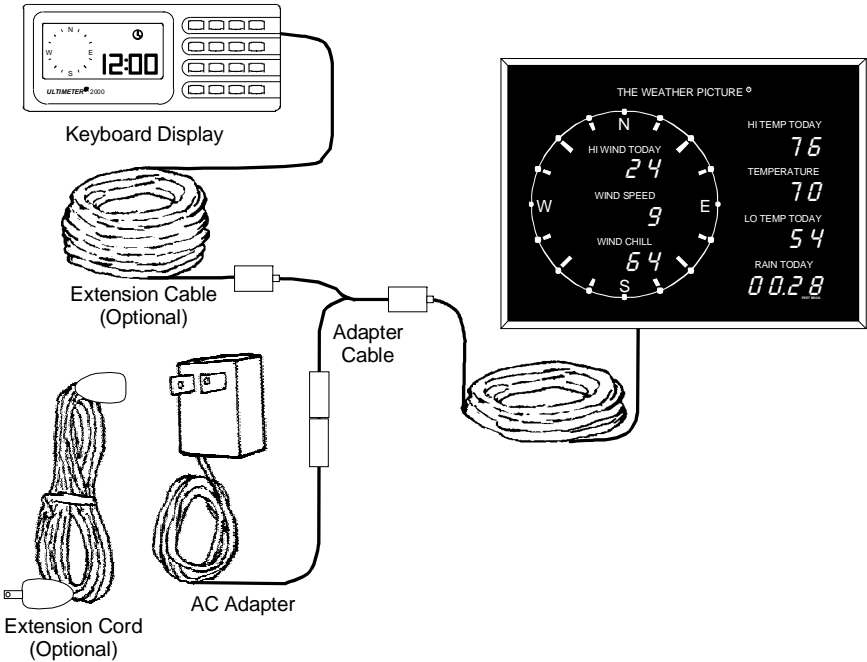

NOTE: BEFORE YOU INSTALL PLUGS IN RECEPTACLES, be sure to check connectors as shown on p. 11.

WIRING DIAGRAM D

If you have an *ULTIMETER* 2100 with Unimount Sensor Array, or an *ULTIMETER* 800 or 2000, with an Indoor Humidity Sensor connected to the keyboard's serial port, connect components as shown in the following diagram. Use an extension cable (shown) only if you require additional cable length between WEATHER PICTURE and keyboard. A Modular Duplex Cable is required for WEATHER PICTURE and Indoor Humidity Sensor to share the keyboard's serial port. Use Adapter Cable provided.

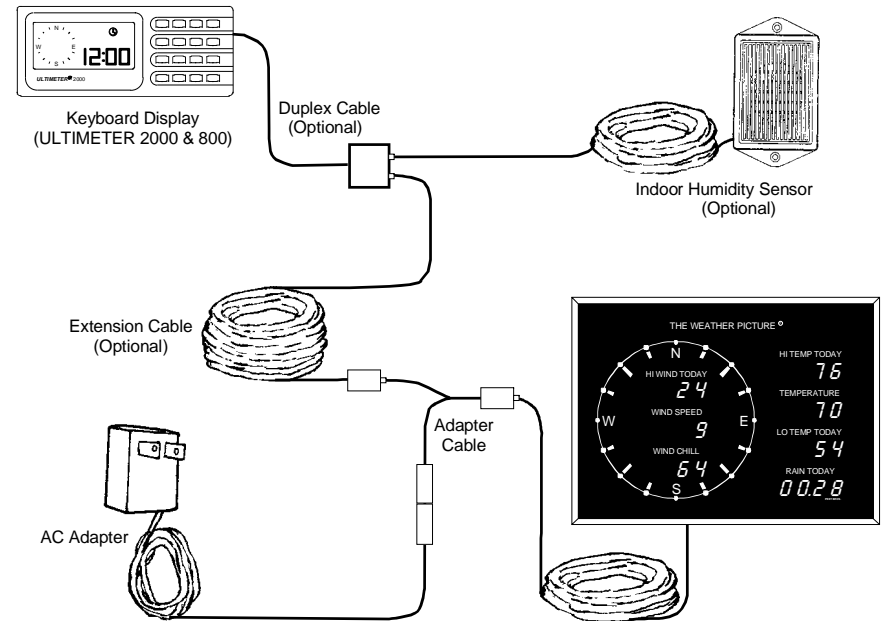

NOTE: BEFORE YOU INSTALL PLUGS IN RECEPTACLES, be sure to check connectors as shown on p. 11.

WIRING DIAGRAM E

If you have an *ULTIMETER* 100 with an Indoor Temperature Sensor connected to the keyboard's serial port, connect components as shown in the following diagram. Use an extension cable (shown) only if you require additional cable length between WEATHER PICTURE and keyboard. A Modular Duplex Cable is required for WEATHER PICTURE and Indoor Temperature Sensor to share the keyboard's serial port. Use Adapter Cable provided.

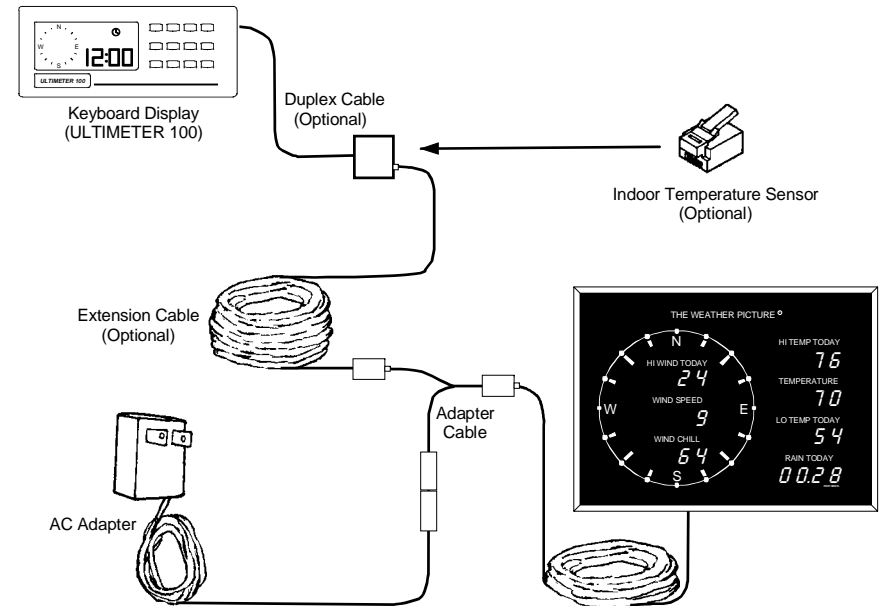

NOTE: BEFORE YOU INSTALL PLUGS IN RECEPTACLES, be sure to check connectors as shown on p. 11.

WIRING DIAGRAM F

If you have an *ULTIMETER II*, 100, 500, 800, 2000, or 2100 with PC Data Logger Interface connected to the keyboard's serial port, connect components as shown in the following diagram. Use an extension cable (shown) only if you require additional cable length between WEATHER PICTURE and keyboard. A Modular Duplex Cable is required for WEATHER PICTURE and PC Data Logger to share the keyboard's serial port. Use Adapter Cable provided.

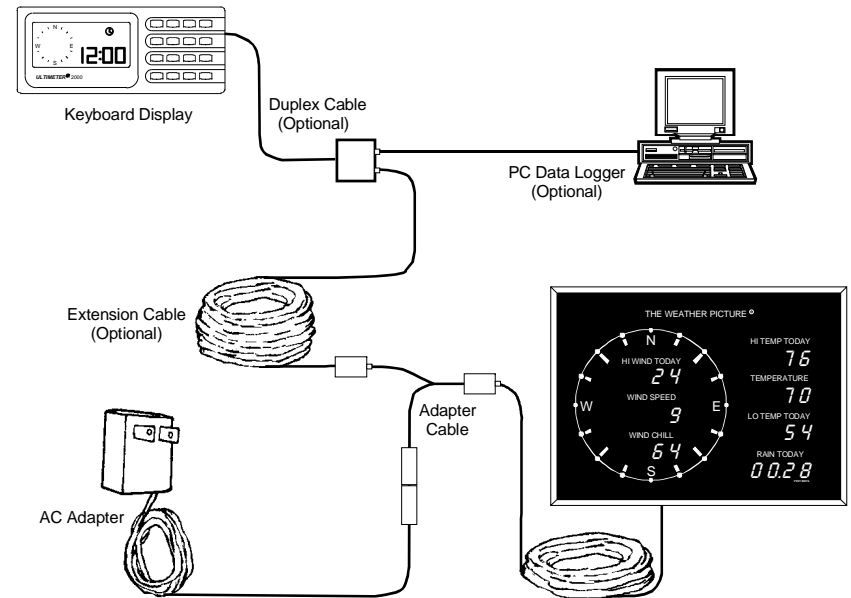

NOTE: BEFORE YOU INSTALL PLUGS IN RECEPTACLES, be sure to check connectors as shown on p. 11.

WIRING DIAGRAM G

If you have an *ULTIMETER* 800, 2000 , or 2100 with an Indoor Humidity Sensor AND PC Data Logger Interface connected to the keyboard's serial port, connect components as shown in the following diagram. Use an extension cable (shown) only if you require additional cable length between WEATHER PICTURE and keyboard. A 5-Jack Extension Cable is required for WEATHER PICTURE, PC Data Logger, and Indoor Humidity Sensor to share the keyboard's serial port. Use Adapter Cable provided.

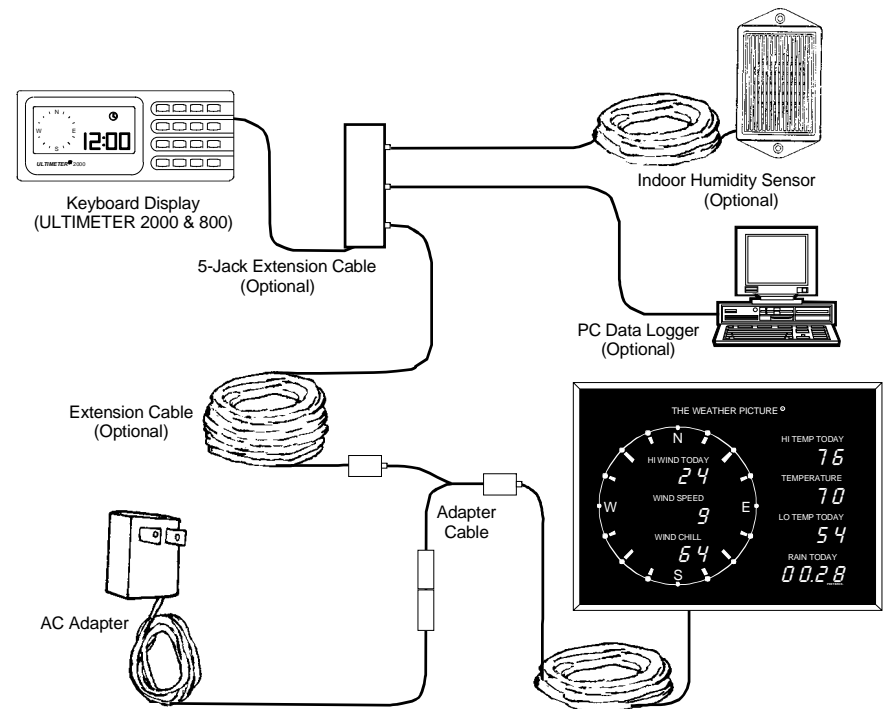

NOTE: BEFORE YOU INSTALL PLUGS IN RECEPTACLES, be sure to check connectors as shown on p. 11.

Check all receptacles for crossed wires (see illustration below). This can occur during plug-in and unplugging of the cables. It can be corrected by using a pair of tweezers to gently lift the wire back into the correct slot.

WRONG

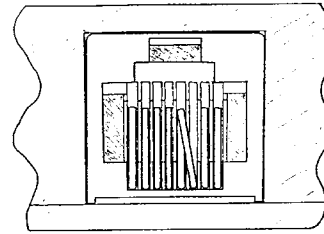

RIGHT

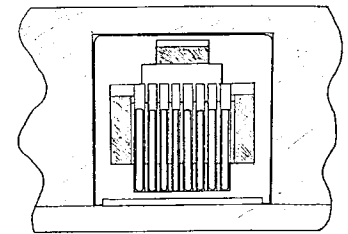

Installing the Wall Mounting Bracket

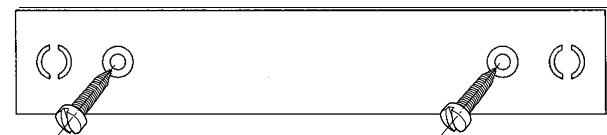

1. Using the mounting bracket as a template, use a pencil to mark two holes 3.75 in. apart for the wood screws or drywall anchors provided. Mount at a height slightly above eye level for best viewing angle.
2. Install the mounting bracket using the two screws provided. Do not overtighten.
3. Hang the WEATHER PICTURE from the two projecting nubs on the mounting bracket.









TO ADJUST TIME, DATE, AND YEAR SETTING

The current time and date displayed on the WEATHER PICTURE are set using the keyboard of the *ULTIMETER* Weather Station. Refer to your Weather Station Owner's Manual for complete information. The selection of 12-hr or 24-hr clock, however, is made on the WEATHER PICTURE. See "Numeric Display Function" section.

The *ULTIMETER*® Weather Stations feature a perpetual calendar. For THE WEATHER PICTURE® to operate correctly, you must adjust the year setting on the Keyboard/Display.

- a) Press and release  and  simultaneously. The clock and calendar symbols will appear on the screen and the instrument will briefly display the year setting (default is 2009).

NOTE: Owners of earlier-model *ULTIMETER* weather stations (purchased prior to 2003) should refer to their weather station Owner's Manual for instructions on "Setting Leap Year Counter"

- b) Press  and KEEP IT PRESSED until the year setting begins to change. Then press  or  as required until the display shows the current year.
- c) Press and release  to set time or  to set date.
- d) Press and hold  or  as required until the displayed value is close to correct, then press repeatedly until correct setting is displayed. Press any data key to return to normal operation.



NOTE: Adjust the year counter BEFORE you set the date. If you have already set the date, check it after setting the year.

SELECTING SERIAL DATA MODE

The serial data output port on the *ULTIMETER* weather stations has two different modes which are used with THE WEATHER PICTURE. The mode can be selected by pressing and holding a combination of two keys. The following is a brief description, to provide an idea of the capabilities of each mode.

DATA LOGGING MODE



In Data Logging Mode, the instrument puts out a steady stream of records, about one per second. Each record includes all current readings, including time and date. Key

Combo: Press and hold  and  for 3 seconds to enter this mode.

COMPLETE RECORD MODE

In Complete Record Mode, the instrument puts out a steady stream of records, about twenty per minute. Each record includes all current values, today's high and low values, yesterday's high and low values, and long term rain values, and current time and date.

The *ULTIMETER* Weather Station must be in Complete Record Mode for the WEATHER PICTURE to display some historical weather data (such as Yesterday's High or Low weather conditions).

If you have selected a function to be displayed on the WEATHER PICTURE that *requires* Complete Record Mode, but are operating the keyboard in Data Logging Mode, the error code "**Err4**" will appear in the red numeric display. Change to Complete Record Mode by the following key combo: Press and hold  and  for 3 seconds to enter this mode. (It may also be necessary to power-down and power-up the WEATHER PICTURE to reset and clear the error.)

NOTE: It is essential to make the correct Year setting (see previous section); otherwise, date data from the serial port may be incorrect.

IV. SELECTING NUMERIC DISPLAY FUNCTIONS

The Numeric Displays of the WEATHER PICTURE are individually set to display one of sixty different weather functions. The desired function and the measurement units are selected by setting a series of switches (DIP switch), found beside each Numeric Display on the front of the WEATHER PICTURE (behind the nameplate).

To access the DIP switches, follow the procedure for removing the frame found in the next section, "Changing Numeric Display Labels."

The DIP switches are numbered as follows (shown all "ON"):

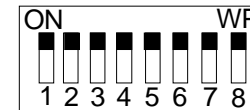

Switches 1-6 are used to select the desired data and measurement units; switches 7 and 8 are used to select the format for time and date displayed.

CAUTION: Turn off power (On/Off switch located on bottom edge of Weather Picture) before adjusting DIP switches. When you first reapply power, be sure the correct "CHECK VALUE" is displayed in the Numeric Display.

SETTING DATE FORMAT

1. If you prefer a MM/DD date display, turn switch 7 "ON" ↑.
2. If you prefer a DD/MM date display, turn switch 7 "OFF" ↓.

SET TIME FORMAT

1. If you prefer a 24-hr clock display, turn switch 8 "ON" ↑.
2. If you prefer a 12-hr clock display (a.m. & p.m.) display, turn switch 8 "OFF" ↓.

SELECTING UNITS (US/Metric)

Units are selected for each weather function individually, by DIP switch setting. Refer to the list of switch settings to display a weather function using the desired units (Fahrenheit/Celsius, Knots/MPH, inHg/mbar, etc.).

CHANGING NUMERIC DISPLAY LABELS

A sheet of additional function labels is provided for customizing the data display of your WEATHER PICTURE. Use scissors to cut the labels (up to the black edge). Labels are designed to remain in place when installed, but double-sided tape may be used if desired to keep a function label in position. To change a label:

- 1) Place the WEATHER PICTURE face down on a soft flat surface. Laying a soft towel down first is recommended to help prevent scratching the nameplate. On Metal Frames: Loosen the 8 screws in the corner brackets of the frame. On Oak Frames: Loosen the frame retaining clip screws and rotate the clips to allow removal of the frame.
- 2) Turn the WEATHER PICTURE face up again. On Metal Frames: Remove the metal frame from around the WEATHER PICTURE by pulling the four frame parts away from the WEATHER PICTURE housing. On Oak Frames: Lift frame up from the housing.
- 3) Carefully lift the nameplate out and set it aside.
- 4) Replace Display Function Labels as desired, using double-sided tape to retain them if necessary.
- 5) Carefully replace nameplate in the slight recess of the housing front.
- 6) Metal Frames Only: Install corner brackets in the two short frame parts. Replace the long frame parts on their respective sides of the housing. Then replace the short parts (with corner brackets).
- 7) Once again, place the WEATHER PICTURE face down on a soft flat surface. On Metal Frames: Tighten the corner bracket screws. On Oak Frames: Rotate the frame retaining clips and gently tighten the screws. Do not overtighten.

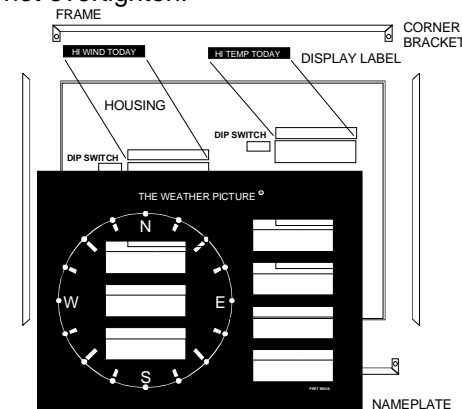

SWITCH SETTINGS (↑ = ON, ↓ = OFF)

<u>FUNCTION & UNITS</u>	<u>SWITCH:</u>	<u>1</u>	<u>2</u>	<u>3</u>	<u>4</u>	<u>5</u>	<u>6</u>	<u>CHECK</u> <u>VALUE</u>
CURRENT TIME AND DATE		↓	↑	↑	↑	↑	↑	1
CURRENT WIND SPEED (mph)		↑	↓	↑	↑	↑	↑	2
CURRENT WIND SPEED (kph)		↓	↓	↑	↑	↑	↑	3
CURRENT WIND SPEED (m/s)		↑	↑	↓	↑	↑	↑	4
CURRENT WIND SPEED (knots)		↓	↑	↓	↑	↑	↑	5
1 MINUTE WIND SPEED AVERAGE (mph)		↓	↓	↓	↑	↑	↑	7
1 MINUTE WIND SPEED AVERAGE (kph)		↑	↑	↑	↓	↑	↑	8
1 MINUTE WIND SPEED AVERAGE (m/s)		↓	↑	↑	↓	↑	↑	9
1 MINUTE WIND SPEED AVERAGE (knots)		↑	↓	↑	↓	↑	↑	10
PEAK SPEED OVER LAST 5 MINUTES (mph)		↓	↓	↑	↓	↑	↑	11
PEAK SPEED OVER LAST 5 MINUTES (kph)		↑	↑	↓	↓	↑	↑	12
PEAK SPEED OVER LAST 5 MINUTES (m/s)		↓	↑	↓	↓	↑	↑	13
PEAK SPEED OVER LAST 5 MINUTES (knots)		↑	↓	↓	↓	↑	↑	14
TODAY'S HIGH WIND SPEED (mph) WITH TIME OCCURRED		↓	↓	↓	↓	↑	↑	15
TODAY'S HIGH WIND SPEED (kph) WITH TIME OCCURRED		↑	↑	↑	↑	↓	↑	16
TODAY'S HIGH WIND SPEED (m/s) WITH TIME OCCURRED		↓	↑	↑	↑	↓	↑	17
TODAY'S HIGH WIND SPEED (knots) WITH TIME OCCURRED		↑	↓	↑	↑	↓	↑	18
WIND DIRECTION IN DEGREES (0°=NORTH)		↑	↑	↓	↓	↓	↓	60
CURRENT WIND CHILL TEMPERATURE (°F)		↓	↓	↑	↑	↓	↑	19
CURRENT WIND CHILL TEMPERATURE (°C)		↑	↑	↓	↑	↓	↑	20
TODAY'S LOW WIND CHILL TEMP (°F) WITH TIME OCCURRED		↓	↑	↓	↑	↓	↑	21
TODAY'S LOW WIND CHILL TEMP (°C) WITH TIME OCCURRED		↑	↓	↓	↑	↓	↑	22
CURRENT OUTDOOR TEMPERATURE (°F)		↓	↓	↓	↑	↓	↑	23
CURRENT OUTDOOR TEMPERATURE (°C)		↑	↑	↑	↓	↓	↑	24
TODAY'S LOW OUTDOOR TEMP (°F) WITH TIME OCCURRED		↓	↑	↑	↓	↓	↑	25
TODAY'S LOW OUTDOOR TEMP (°C) WITH TIME OCCURRED		↑	↓	↑	↓	↓	↑	26
TODAY'S HIGH OUTDOOR TEMP (°F) WITH TIME OCCURRED		↓	↓	↑	↓	↓	↑	27
TODAY'S HIGH OUTDOOR TEMP (°C) WITH TIME OCCURRED		↑	↑	↓	↓	↓	↑	28
CURRENT OUTDOOR HUMIDITY (%)		↓	↓	↑	↑	↑	↓	35
TODAY'S LOW OUTDOOR HUMIDITY (%) WITH TIME OCCURRED		↑	↓	↓	↑	↑	↓	38

<u>FUNCTION & UNITS</u>	<u>SWITCH:</u>						<u>CHECK</u>
	<u>1</u>	<u>2</u>	<u>3</u>	<u>4</u>	<u>5</u>	<u>6</u>	<u>VALUE</u>
TODAY'S HIGH OUTDOOR HUMIDITY (%) WITH TIME OCCURRED	↓	↓	↓	↑	↑	↓	39
CURRENT BAROMETER (inHg)	↓	↑	↓	↓	↓	↑	29
CURRENT BAROMETER (mmHg)	↑	↓	↓	↓	↓	↑	30
CURRENT BAROMETER (mBar)	↓	↓	↓	↓	↓	↑	31
CURRENT BAROMETER (Hpa)	↓	↓	↓	↓	↓	↑	31
3 HOUR PRESSURE CHANGE (inHg)	↑	↑	↑	↑	↑	↓	32
3 HOUR PRESSURE CHANGE (mmHg)	↓	↑	↑	↑	↑	↓	33
3 HOUR PRESSURE CHANGE (mBar)	↑	↓	↑	↑	↑	↓	34
3 HOUR PRESSURE CHANGE (Hpa)	↑	↓	↑	↑	↑	↓	34
CURRENT DEW POINT TEMPERATURE (°F)	↑	↑	↓	↑	↑	↓	36
CURRENT DEW POINT TEMPERATURE (°C)	↓	↑	↓	↑	↑	↓	37
TODAY'S RAIN TOTAL (inches)	↑	↓	↑	↓	↑	↓	42
TODAY'S RAIN TOTAL (mm)	↓	↓	↑	↓	↑	↓	43
YESTERDAY'S RAIN TOTAL (inches) & DATE	↑	↑	↓	↓	↑	↓	44
YESTERDAY'S RAIN TOTAL (mm) & DATE	↓	↑	↓	↓	↑	↓	45
LONG TERM RAIN TOTAL (inches) SINCE DATE	↑	↓	↓	↓	↑	↓	46
LONG TERM RAIN TOTAL (mm) SINCE DATE	↓	↓	↓	↓	↑	↓	47
LONG TERM EVAPOTRANSPIRATION (0.01inches)	↑	↑	↑	↓	↑	↓	40
LONG TERM EVAPOTRANSPIRATION (0.1mm)	↓	↑	↑	↓	↑	↓	41
CURRENT INDOOR TEMPERATURE (°F)	↑	↑	↑	↑	↓	↓	48
CURRENT INDOOR TEMPERATURE (°C)	↓	↑	↑	↑	↓	↓	49
TODAY'S LOW INDOOR TEMP (°F) WITH TIME OCCURRED	↑	↓	↑	↑	↓	↓	50
TODAY'S LOW INDOOR TEMP (°C) WITH TIME OCCURRED	↓	↓	↑	↑	↓	↓	51
TODAY'S HIGH INDOOR TEMP (°F) WITH TIME OCCURRED	↑	↑	↓	↑	↓	↓	52
TODAY'S HIGH INDOOR TEMP (°C) WITH TIME OCCURRED	↓	↑	↓	↑	↓	↓	53
CURRENT INDOOR HUMIDITY (%)	↑	↓	↓	↑	↓	↓	54
TODAY'S LOW INDOOR HUMIDITY (%) WITH TIME OCCURRED	↓	↓	↓	↑	↓	↓	55
TODAY'S HIGH INDOOR HUMIDITY (%) WITH TIME OCCURRED	↑	↑	↑	↓	↓	↓	56
CURRENT HEAT INDEX (°F)	↓	↑	↑	↓	↓	↓	57
CURRENT HEAT INDEX (°C)	↑	↓	↑	↓	↓	↓	58
SOLAR RADIATION (W/m2)	↑	↑	↑	↑	↑	↑	0
X-SENSOR (%)	↓	↓	↑	↓	↓	↓	59
UV RADIATION (W/m2)	↓	↑	↓	↓	↓	↓	61
UV INDEX	↑	↓	↓	↓	↓	↓	62

V. ROUTINE MAINTENANCE

Care of Nameplate

The large nameplate on the front side of the WEATHER PICTURE should be cleaned with a soft damp cloth only. Use no harsh or abrasive cleaners, as these will permanently scratch the surface of the nameplate. Do not spray any liquids or cleaners directly on the nameplate.

In Case of Non-Responsive WEATHER PICTURE

Sometimes an electrical storm or line power surge can cause the weather station keyboard or WEATHER PICTURE to be disabled. To correct this condition, press the On/Off switch to power down and power up again, or unplug the WEATHER PICTURE's power cord from its AC adapter, and re-plug to power up again. If this does not correct the problem, unplug the junction box cable from the back of the weather station keyboard display and remove the 9-volt battery (however, be advised that all memories and initial settings will be lost). Install the battery again and reconnect the junction box cable.

Error Codes

On occasion an error code may appear in a Numeric Display:

<u>Code</u>	<u>Meaning</u>	<u>Corrective Action</u>
Err1	Invalid DIP Switch Setting	Correct DIP switch setting; see Section IV "Selecting Numeric Display Functions".
Err2	No Serial Input	Check wiring diagram, cable connections from Weather Station keyboard, or Display Module wire harness connectors.
Err3	Keyboard in Packet Mode	Change Serial Port to Complete Record or Data Logger Mode.
Err4	Keyboard not in Complete Record Mode	Change Serial Port to Complete Record Mode.
Err5	Sensor Not Found	Correct DIP switch setting or add required weather sensor.
Err8	Unexpected Interrupt	Call Technical Support.

VI. WARRANTY

In Case of a Problem

Your WEATHER PICTURE is designed to provide years of trouble free operation. If the instrument completely stops operating, the cause is probably inadequate power due to a faulty AC adapter, or a faulty connection to the adapter.

Also, be sure to see page 12 (crossed wires in receptacles).

If a problem persists, please write or call our Technical Service Department at (866) 446-1216. We will do everything possible to assure your satisfaction.

Repair and Exchange Service

Any defective WEATHER PICTURE may be repaired or exchanged for a factory reconditioned instrument of the same type with like-new performance. Under warranty there is no charge. Beyond warranty the charges are modest, depending upon the condition of the instrument.

Copyright 2007 Peet Bros. Company, Inc. All Rights Reserved.

WARRANTY

Each WEATHER PICTURE carries a limited warranty against defects of material or workmanship for a period of 1 year from the date of initial purchase. Our responsibility under this warranty is limited to the repair or replacement of instruments returned to us postage paid, together with proof of purchase date. This warranty shall not apply to instruments subjected to: improper installation, any alterations, misuse, tampering, or unauthorized service. It does not cover damage to the frame or nameplate, or damage due to accidents, lightning, or other acts of God. Neither we nor our representatives, distributors, nor dealers shall be liable for any incidental or consequential damages. Some states do not allow the exclusion or limitation of incidental or consequential damages, so the above exclusion or limitation may not apply to you. This warranty gives you specific legal rights, and you may also have other rights which vary from state to state.

VII. SPECIFICATIONS

Wind

Speed Range: 0 to 274 km/h
0 to 170 mph
0 to 76 m/s
0 to 148 knots
Accuracy: ± 5 @ 274 km/h
 ± 3 @ 170 mph
 ± 2 @ 76 m/s
 ± 3 @ 148 knots
Direction: 16 point analog
"compass rose" display

Outdoor Temperature

Range:- -55 to +150 degrees F.
-48 to +66 degrees C.
Accuracy: ± 2 degrees F.
 ± 1 degree C.

Indoor Temperature

Range:- 32 to 110 degrees F.
0 to 43 degrees C.
Accuracy: ± 2 degrees F.
 ± 1 degree C.

Wind Chill

Range:- -150 to +98 degrees F.
-101 to +37 degrees C.

Rain (with optional sensor)

Units: inches, millimeters
Increments: 0.1", 0.01", 2.5mm,
.25mm, 0.1mm
(user selectable to match rain gauge
increments)

Barometric Pressure (with optional sensor)

Range: 931.3 to 1067.0 hPa/mbar
27.5 to 31.5 inHg
698.5 to 800.0 mmHg
Accuracy: ± 1.7 hPa/mbar
 ± 0.05 inHg (1.3 mmHg)
(at room temperature)

Outdoor Humidity (with optional sensor)

Relative Humidity Range: 0 to 100%
R.H. Accuracy: $\pm 5\%$ of full scale
Dew Point: same units as
temperature

Indoor Humidity (with optional sensor)

R.H.: same as for Outdoor Humidity

Display Unit

Size: 1" x 4"
Display: Red Illuminated LED
Numeral Size: .8" high
Wall Mounted

Primary Power

AC adapter 12v/1a DC output, center
pin positive

Optional Accessories

- Additional Numeric Displays
- Wireless Display Kit
- Teak Frame
- Custom Nameplates
- Size Upgrades

Specifications necessarily subject to change.

VIII. AVAILABLE ACCESSORIES

We are continually developing new products and accessories to make your *ULTIMETER* Weather Station more interesting and valuable to you. Some of our most popular items are:

Oak Frame

An optional frame with the warmth and durability of genuine oak. Includes gold-accent nameplate.

Custom Nameplate

Custom Nameplates are available for personalizing your WEATHER PICTURE with the name of your location or establishment. Perfect for schools, hotels, country clubs, marinas, ski lodges, emergency management facilities, etc.

PC Data Logger

Special cable and software to record weather data on a personal computer. Features 4 simultaneous graphs of weather conditions over the last 20 hours, updated every five minutes. Or, you can display data from any selected part of the log file in graphic or tabular form.

Extension Cables

Allows greater flexibility in mounting location by increasing the distance between the WEATHER PICTURE and the weather station's keyboard/display.

Wireless Weather Display (WWD) Kit

Includes RF transmitter and receiver for "cable-less" connection between the WEATHER PICTURE and the weather station's keyboard/display, such as for mounting in another room or different floor of a building.

Duplex Cable

Allows both an indoor humidity sensor and a data logger cable or other serial I/O device to be connected simultaneously with the WEATHER PICTURE to the receptacle on the right side of the keyboard. A 5-Jack Cable is also available.

Radio Frequency Interference Filter

If the WEATHER PICTURE is used near an extremely powerful radio transmitter, its readings can be affected. This would normally only be encountered in the immediate vicinity of commercial radio or TV stations, or high-power ham radio

transmitters. If you think you are experiencing this problem, please inquire about our inexpensive, 30 dB 4-line RFI filter.

For additional information about these or other accessories, please contact your WEATHER PICTURE dealer or Peet Bros. Company. We'll be happy to advise you of latest developments and answer any questions you may have.